

chorder®

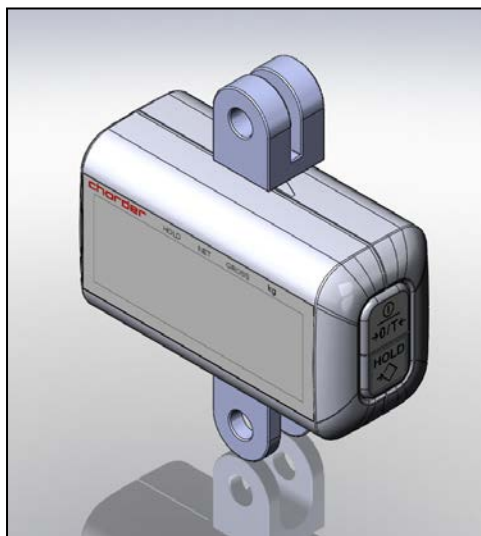

MHS 2500

MANUAL – ENGLISH

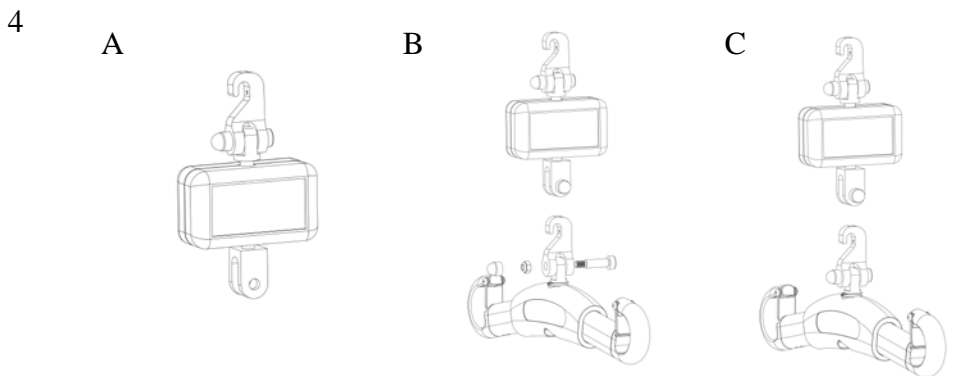
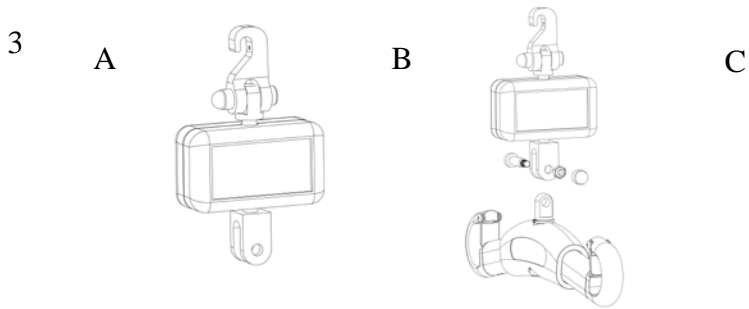
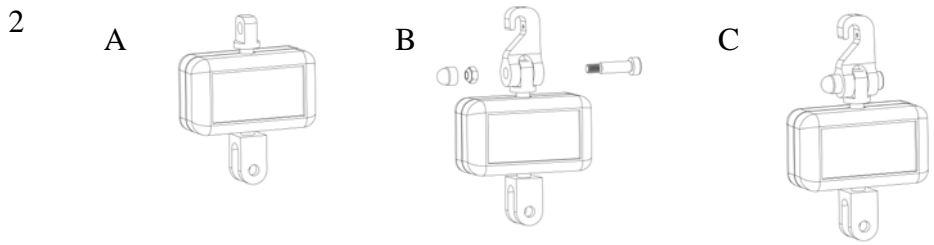
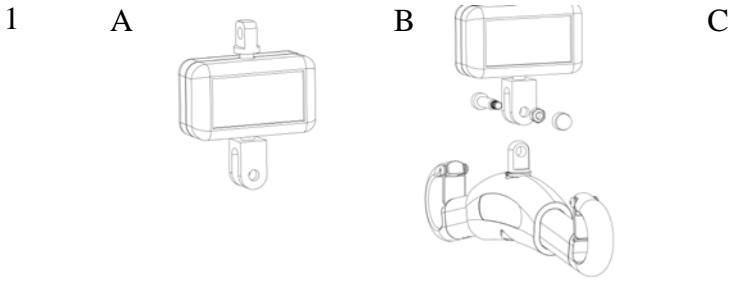

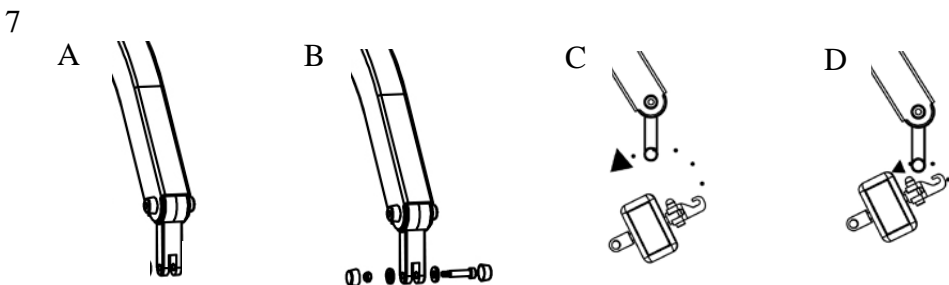
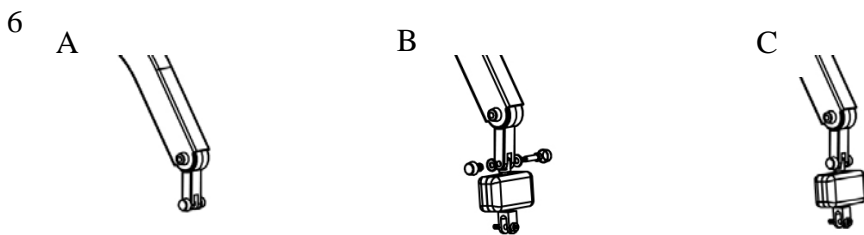
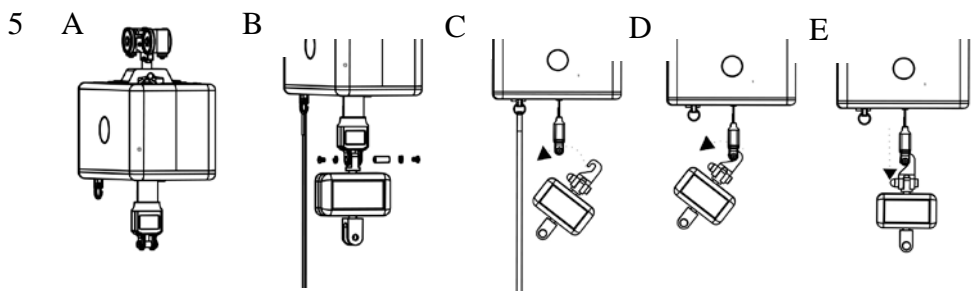
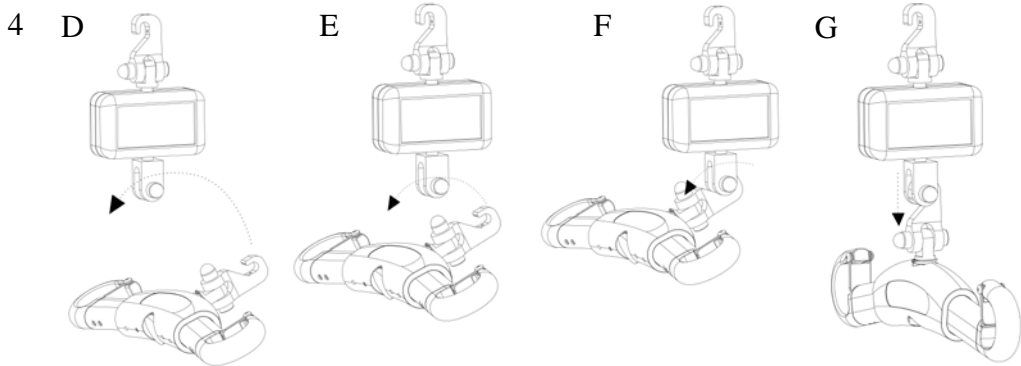



CAUTION

- TILT ANGLE OVER 3° WILL CAUSE FALSE READING.

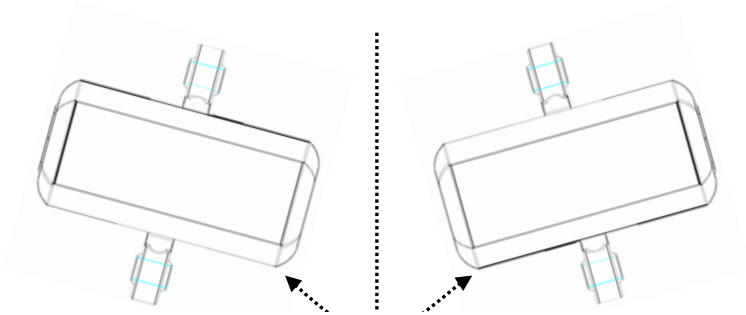

Limited Angle

- Cardon joints are assembled with loadcell from ex-factory. It should not be twisted by user or in any other circumstance. **Misusage will cause unexpected danger.**

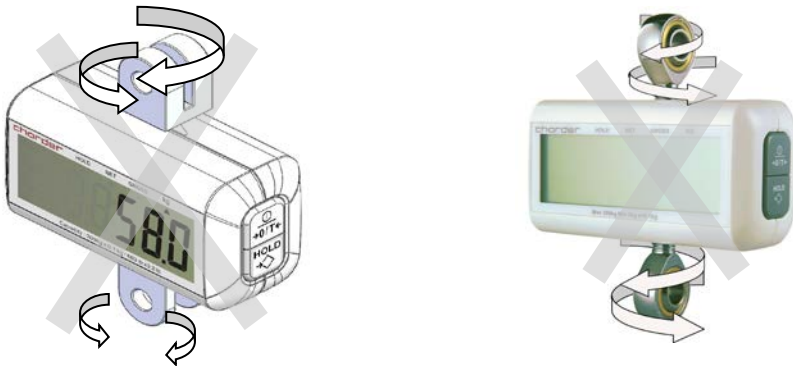

- We do not recommend to build in a scale into the construction of any lift or Hoist that hanger bar do not swivel 360 degrees.

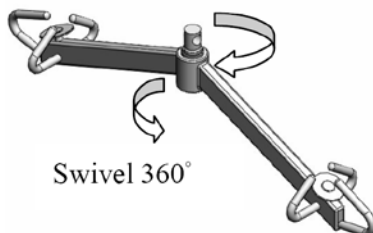

Swivel 360°

TABLE OF CONTENTS

PREFACE.....	2
GENERAL INFORMATION	2
SAFETY INSTRUCTION	2
ENVIRONMENTAL SAFETY.....	3
CLEANING.....	3
MAINTENANCE.....	3
WARRANTY-LIABILITY	4
RECYCLING	5
READING BEFORE USE	5
SPECIFICATIONS.....	6
PANEL INDICATION.....	7
KEY FUNCTIONS.....	8
FEATURE SETTINGS.....	8
OPERATION FLOW.....	9
SETTING UP YOUR SCALE STEP BY STEP.....	10
INSTRUCTION FOR REPLACING BATTERY	11
ERROR MESSAGE	12

PREFACE

Thank you for choosing CHARDER MEDICAL product. All features of this product were designed to state of the art and are optimized for simple and straightforward use. If you have any queries or experience any problems not addressed in the operating instructions, please contact your CHARDER MEDICAL service partner, or visit us on the Internet at www.chardermedical.com

GENERAL INFORMATION

We strongly recommend you use the scales on flat and hard surface. Any soft surface, like carpet will cause inaccuracy.

SAFETY INSTRUCTION

Before putting the device into use, please read with care the information given in the following instruction. They contain important instructions for installation, proper use and maintenance of the device.

The manufacturer shall not be liable for damages arising out of failure to heed the following instructions:

- *When using electrical components under increased safety requirements, always comply with the appropriate regulations. Improper installation will render the warranty null and void.
- *This device is designed for use indoors.
- *Observe the permissible ambient temperatures for use.
- *The device meets the requirements for electromagnetic compatibility. Do not exceed the maximum values specified in the applicable standards.
- *Ensure that the patient does not lean against the device risk of falling!
 - If you have any problem, contact your local CHARDER MEDICAL service partner

ENVIRONMENTAL SAFETY

- All batteries contain toxic compounds. Disposal of batteries should be delegated to a competent organization, complying with the deposit of Poisonous Waste Regulation 1972. Please do not incinerate batteries.
- You are legally obliged to hand in used batteries/rechargeable batteries to a local collection point so that they can be disposed of in an environmentally-friendly way. When buying new batteries, select batteries low in harmful substances and no mercury (Hg), cadmium (Cd) or lead (Pb).

CLEANING

- We would recommend using alcohol based wipes or similar when cleaning the scales.
- Please do not use large amounts of water when cleaning the scales as this will cause damage to electronics, you should also refrain from using corrosive liquids or high pressure washers.
- Always turn off the scale before cleaning.

MAINTENANCE

The scale does not require any routine maintenance. However, we recommend checking the scale's accuracy at regular intervals. The regularity of these checks is dependent on the level of use and the state of the scale. If any inaccuracies occur, please contact your local dealer or CHARDER MEDICAL service partner.

WARRANTY-LIABILITY

If a fault or defect is presented on receipt of the unit which is within CHARDER MEDICAL's scope of responsibility, CHARDER shall have the right to either repair the fault or supply a replacement unit. Replaced parts shall be the property of CHARDER. Should the fault repairs or replacement delivery not be successful, the statutory provisions shall be valid. The period of warranty shall be two years, beginning on the date of purchase. Please retain your receipt as proof of purchase. Should your scale require servicing, please contact local distributor or CHARDER MEDICAL Customer Service.

No responsibility shall be accepted for damage caused through any of the following reasons: Unsuitable or improper storage or use, incorrect installation or commissioning by the owner or third parties, natural wear, changes or modifications, incorrect or negligent handling , overuse, chemical, electrochemical or electrical interference or humidity, unless this is attributable to negligence on the part of CHARDER MEDICAL.

If operating, climatic or any other influences lead to a major change in conditions or material quality, the treaty for perfect unit functioning shall be rendered null and void. If CHARDER provides an individual warranty, this means that the unit supplied will be free of faults for the length of the warranty period.

RECYCLING

This product is not to be treated as regular household waste, but should be handed into an electrical/electronic equipment recycling centre.

You can obtain further details from your local council, your municipal waste disposal company or the firm which you purchased the product.

READING BEFORE USE

Before reading detailed instructions on how to use all the weighing functions that are built into your scale, please read the following important guidelines:

*Always be sure that the display shows `Zero` before use, if it does not then please press ZERO key to reset.

*MHS scale is ideal for Patient Lifter / Mobility / Hi-Trac Lifter.

Note: Do not measure weight during movement, tilt will cause inaccuracy.

SPECIFICATIONS

MODEL : MHS 2500

Capacity	200kg / 300kg	400kg
Division	0.1kg	0.2kg
Display options	1.0 inch 5 and 1/2 digits	
Weight Unit	kg	
Dimension	120 x 50 x 160 mm	
Power	1.5V AAA * 6 batteries	
Operating Temperature	0-40°C	

WARNING!

*Only kg unit is approved by OIML(International Organization of Legal Metrology).

PANEL INDICATION

HOLD indicator

NET weight

Gross weight

kg unit indicator

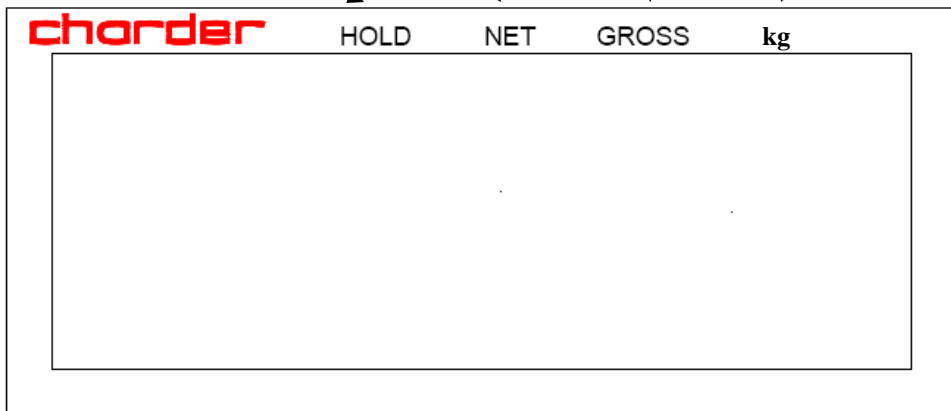
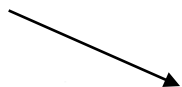

KEY FUNCTIONS

ON/OFF/ZERO/TARE

TARE function is designed for people who want to subtract additional weight (like clothing) from total weight to get the net weight of subject.

How to get net weight?

Loading the weight you want to subtract from a person. Press **ON/OFF/ZERO/TARE** key to tare the weight. Then you will get net weight when lift a person.

Key description : **ON/OFF/ZERO/TARE**

- Press to switch on and depress 3 seconds to switch off.
- Press to reset if weight is within $\pm 2\%$ of full capacity.
- Press to tare the weight and acquire net weight.
-

HOLD

- When HOLD function is enabled, scale will sample 5 to 10 sets of reading and analyze the discrepancy. If discrepancy is less, scale will sample current weight as its real weight. Reading can be taken now.
- Key Description:
- Press to keep the result during weighing process.

To disable the hold function, press **HOLD** key again

FEATURE SETTINGS

Auto-Off Time Adjustment

Device will automatically off according auto-off time setting.

Auto-Off setting time: 120 sec/180 sec/240 sec/300 sec/off

Buzzer Adjustment

Switching the buzzer **ON** and **OFF**.

OPERATION FLOW

Please follow the operation flow to set up your scale.

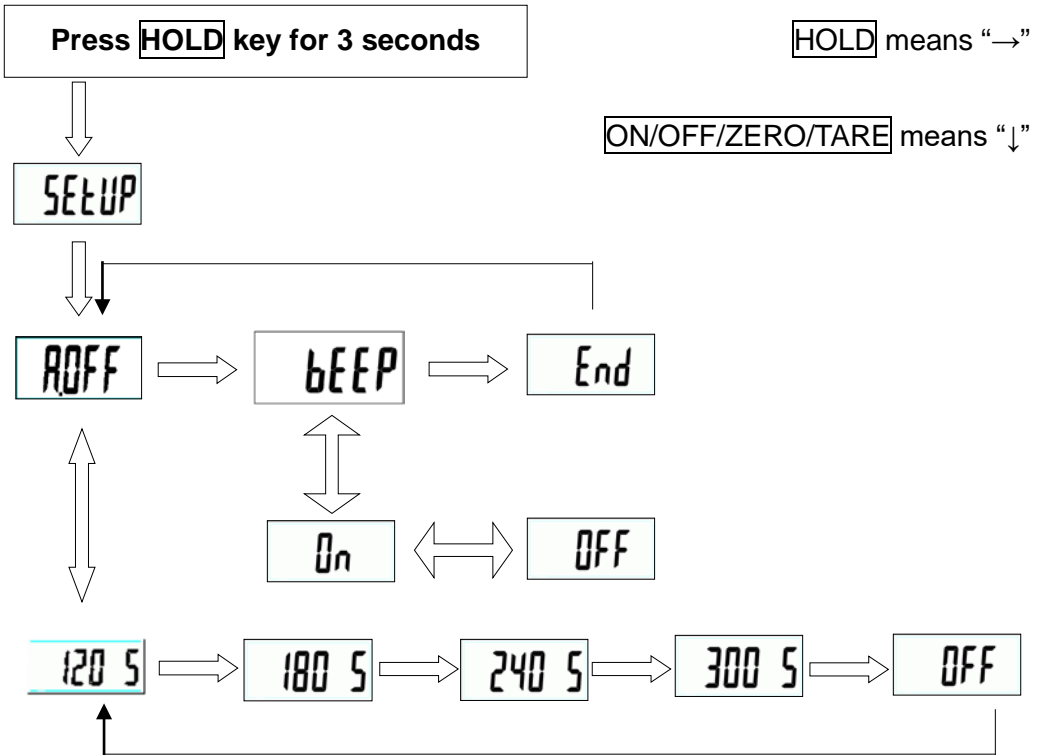

SETTING UP YOUR SCALE STEP BY STEP

For Example: Set up 180s AUTO-OFF time and Buzzer OFF

Step 1.

Press **HOLD** for 3 seconds to enter **SETUP** setup mode.

Step 2.

Press **ZERO** to enter **ROFF** mode when **ROFF** is displayed.

Step 3.

Press **HOLD** to select **180 5** which means AUTO-OFF TIME is 180 seconds.

Step 4.

Press **ZERO** to decide and return to **ROFF** mode and press **HOLD** to shift to **bEEP** setup mode.

Step 5.

Press **ZERO** to enter **bEEP** setup mode and press **HOLD** again to select between **On** and **OFF**.

Step 6.

Press **ZERO** to decide and return to **bEEP** set up mode.

Step 7.

Press **HOLD** to select **End** and press **ZERO** to finish setting.

INSTRUCTION FOR REPLACING BATTERY

MHS Series uses six AAA size alkaline batteries. Please read the following instruction before using the scale.

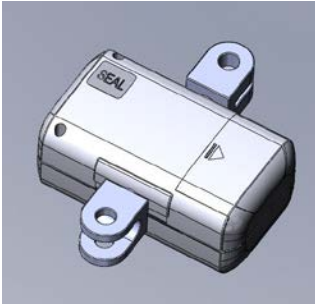

1. Find the battery cover at the back side of scale

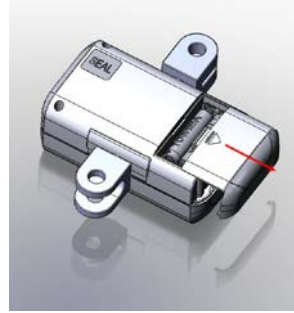

2. Remove the battery cover.

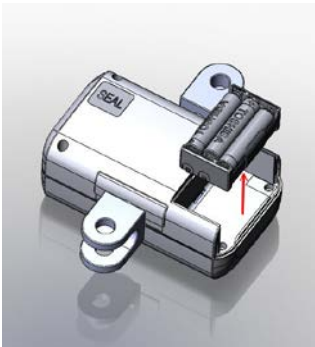

3. Take the battery case out.

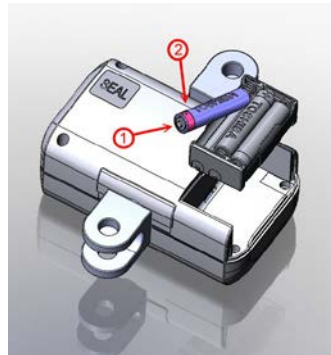

4. Installing 6* AAA size batteries.

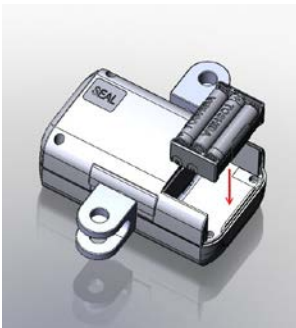

5. Installing the battery case.

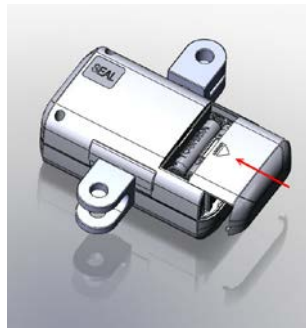

6. Installing the battery cover.

ERROR MESSAGE

■ **LOW BATTERY INDICATION**

This warning show that the voltage of battery is too low to operate. Please change battery.



■ **ZERO HIGH**

The loading is over limited when power on, please reduce the loading.



■ **ZERO LOW**

The loading is under limited when power on, please increase the loading.



■ **OVER LOAD or COUNTING ERROR**

The loading is over limit, please reduce the loading and try again.
If the trouble still exists, please call the service.



■ **COUNTING ERROR (too low)**

The loading is lower than limit when power on, please increase the loading and try again.
If the trouble still exists, please call the service.

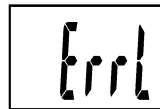

■ **EEPROM ERROR**

The programs of the scale is error, please call the service.





Manufacturer's Declaration of Conformity

This product has been manufactured in accordance with the harmonized European standards, following the provisions of the below stated directives:

Electro Magnetic Compatibility Directive 2004/108/EC
Low Voltage Directive 2006/95/EC

only Medical Approval Scale is in conformity with
Medical Directive 93/42/EEC

FCC CLASS B Declaration of Conformity

This device complies with the limits for a Class B digital device, pursuant to Part 15 of the FCC Rules

Authorized EU Representative:

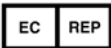

Pedihealth Oy
Kastellinmaenkuja 8,
FI-90230 OULU,
Finland

Manufactured by:



Charder Electronic Co., Ltd.
No.103, Kuo Chung Road, Dah Li City,
Taichung Hsien, Taiwan (R.O.C.)

FDA no.: D072479 / 3007074192

This product is supplied by Handicare AB as part of the SystemRoMedic range.

SystemRoMedic™

For 25 years we have applied ourselves wholeheartedly to developing smart and easy-to-use assistive devices for easy transfers and to making life and work easier for both patients and personnel in the care sector.

Experience, innovation and training are the basis for SystemRoMedic, a total solution for every imaginable transfer situation.

Transfer: products for moving patients between locations.

Positioning: products for repositioning in the same location.

Support: products that provide mobility support.

Lifting: products adapted for lifting.

The philosophy behind SystemRoMedic is to prevent occupational injuries while improving the patient's sense of independence and dignity. Through a combination of training and a complete range of transfer-assistive devices, SystemRoMedic offers the means to improving both the work environment and the quality of care while enabling significant cost savings.

Our mission, to help people, has always been, and will continue to be, the driving force of innovation. We love easy transfers.

Contact your local distributor if you have any questions about the product and its use. See www.handicare.com for a complete list of distributors. Always make sure that you have the right version of the manual. The most recent editions of manuals are available for downloading from our website, www.handicare.com



handicare

Handicare AB
Torshamnsgatan 35
SE-164 40 Kista
SWEDEN

Tel: +46 (0)8-557 62 200
Fax: +46 (0)8-557 62 299
E-mail: info@handicare.se

Internet: www.handicare.com